

**Modular Cooking Range Line
EVO700 4-Hot Plates Electric
Boiling Top Range on Electric Oven**

ITEM # _____

MODEL # _____

NAME # _____

SIS # _____

AIA # _____

**372016 (Z7ECEH4RE0)**4-hot plate (2,6 kW each)
electric range on electric oven
(6 kW)**372128 (Z7ECEH4REN)**4-hot plate (2,6 kW each)
electric range on electric oven
(6 kW)**Short Form Specification****Item No.** _____

To be installed on stainless steel feet with height adjustment up to 50 mm. Four 2.6 kW cast-iron hot plates hermetically sealed to the one-piece top. Stainless steel oven chamber with 3 levels of runners to accommodate 2/1 GN shelves (2 steam pans). Ribbed oven base plate. Exterior panels in stainless steel with Scotch Brite finish. One piece pressed work top in 1.5 mm thick stainless steel. Right-angled side edges to allow flush-fitting junction between units.

Main Features

- The four round 2.6kW cast-iron plates are hermetically sealed to the one-piece top.
- Base compartment consists of an electric standard oven with thick oven door for heat insulation, positioned beneath the base plate.
- Electric oven to have separate thermostats for top and bottom heating elements.
- Stainless steel oven chamber with 3 levels of runners to accommodate 2/1 GN shelves (2 steam pans).
- Ribbed enamelled steel oven base plate.
- The special design of the control knob system guarantees against water infiltration.
- IPx4 water protection.
- Oven thermostat adjustable from 100 °C to 300 °C.

Construction

- All exterior panels in Stainless Steel with Scotch Brite finishing.
- One piece pressed 1.5 mm work top in Stainless steel.
- Model has right-angled side edges to allow flush fitting joints between units, eliminating gaps and possible dirt traps.

APPROVAL: _____

Included Accessories

- 1 of GN2/1 chrome grid for static oven PNC 164250

Optional Accessories

- GN2/1 chrome grid for static oven (only for 372016) PNC 164250
- Junction sealing kit (only for 372016) PNC 206086
- 4 wheels, 2 swivelling with brake (EVO700/900). It is mandatory to install with base supports for feet/wheels. (only for 372016) PNC 206135
- Flanged feet kit (only for 372016) PNC 206136
- Frontal kicking strip for concrete installation, 800 mm (only for 372016) PNC 206148
- Frontal kicking strip for concrete installation, 1000 mm (only for 372016) PNC 206150
- Frontal kicking strip for concrete installation, 1200 mm (only for 372016) PNC 206151
- Frontal kicking strip for concrete installation, 1600 mm (only for 372016) PNC 206152
- Frontal handrail 800 mm (only for 372016) PNC 206167
- Frontal kicking strip, 800 mm (only for 372016) PNC 206176
- Frontal kicking strip, 1000 mm (only for 372016) PNC 206177
- Frontal kicking strip, 1200 mm (only for 372016) PNC 206178
- Frontal kicking strip, 1600 mm (only for 372016) PNC 206179
- Large handrail (portioning shelf) 800 mm (only for 372016) PNC 206186
- Frontal handrail 1200 mm (only for 372016) PNC 206191
- Frontal handrail 1600 mm (only for 372016) PNC 206192
- 4 feet for concrete installation (not for 900 line freestanding grill) (only for 372016) PNC 206210
- Right and left side handrails (only for 372016) PNC 206240
- Pair of side kicking strips (only for 372016) PNC 206249
- Pair of side kicking strips (concrete installation) (only for 372016) PNC 206265
- Water column with swivel arm (water column extension not included) (only for 372016) PNC 206289
- Water column extension (only for 372016) PNC 206291
- Chimney upstand, 800 mm (only for 372016) PNC 206304
- 2 side covering panels, height 700 mm, depth 700 mm (only for 372016) PNC 206319

- Base support for feet or wheels - 800mm (EVO700/900) (only for 372016) PNC 206367
- Base support for feet or wheels - 1200mm (EVO700/EVO900) (only for 372016) PNC 206368
- Base support for feet or wheels - 1600mm (EVO700/900) (only for 372016) PNC 206369
- Rear paneling - 800mm (EVO700/900) (only for 372016) PNC 206374
- Rear paneling - 1000mm (EVO700/900) (only for 372016) PNC 206375
- Rear paneling - 1200mm (EVO700/900) (only for 372016) PNC 206376
- Chimney grid net, 400mm (only for 372016) PNC 206400

Front

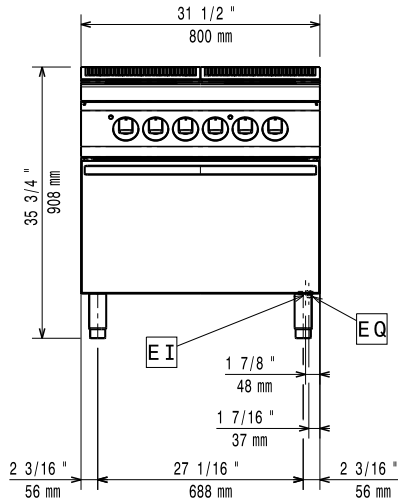

Side

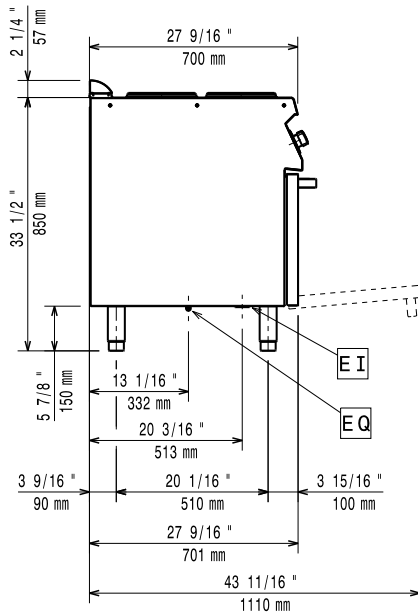

EI = Electrical inlet (power)
EQ = Equipotential screw

Top

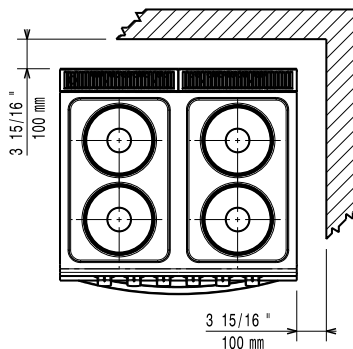

Electric

Supply voltage:

372016 (Z7ECEH4RE0)	380-400 V/3 ph/50-60 Hz
372128 (Z7ECEH4REN)	230 V/3 ph/50/60 Hz

Predisposed for:

Total Watts: 16.4 kW

Key Information:

If appliance is set up or next to or against temperature sensitive furniture or similar, a safety gap of approximately 150 mm should be maintained or some form of heat insulation fitted.

Oven working Temperature: 100 °C MIN; 300 °C MAX

Oven Cavity Dimensions (width): 540 mm

Oven Cavity Dimensions (height): 300 mm

Oven Cavity Dimensions (depth): 650 mm

Net weight: 80 kg

Shipping weight:

372016 (Z7ECEH4RE0)	93 kg
372128 (Z7ECEH4REN)	95 kg

Shipping height:

372016 (Z7ECEH4RE0)	1080 mm
372128 (Z7ECEH4REN)	1140 mm

Shipping width:

820 mm

Shipping depth:

860 mm

Shipping volume:

372016 (Z7ECEH4RE0)	0.76 m ³
372128 (Z7ECEH4REN)	0.8 m ³

Certification group:

372016 (Z7ECEH4RE0)	EH740
372128 (Z7ECEH4REN)	N7CE1

Front Plates Power: 2.6 - 2.6 kW

Back Plates Power: 2.6 - 2.6 kW

Front Plates dimensions: Ø 230 Ø 230

Back Plates dimensions: Ø 230 Ø 230